



TECHNICAL SPECIFICATIONS		
VOLTS	120	
AMPS	12.5	
WATTS	1465	
HEATER	HIGH	1465 watts
	LOW	750 watts
NO HEATER	22 watts	
LAMPS	QUANTITY	LED
	WATTS	
	TOTAL WATTS	22 watts
ROTOR MOTOR	1 at 5 watts	
HEIGHT, WIDTH, DEPTH	26 3/4 x 30 1/4 x 10 1/8	
GLASS VIEWING OPENING		
SURROUND SIZE	32 1/2 x 25 5/8	
SHIPPING SIZE	UNIT	30 x 35 3/4 x 13
	STEEL FRONT	30 x 35 x 3
SHIPPING WEIGHT	UNIT	61.6 lbs
	STEEL FRONT	15 lbs
PLUG LOCATION	Left Side	
CORD LENGTH	76"	
APPROX. HEATING AREA	400 sq ft	



SERIES ZERO CLEARANCE	MODEL ZECL-31-3228-STL-SQR		REV 1
SCALE 1" = 1'-0"	DATE: 12/1/15	SHEET 1 OF 1	

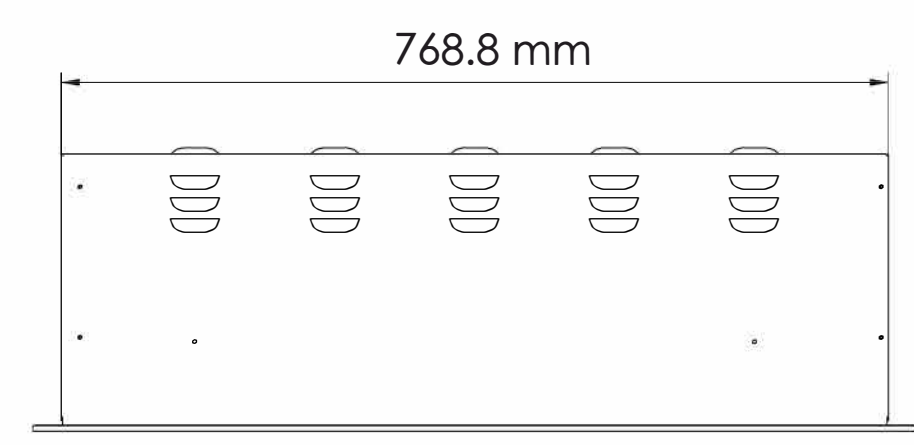
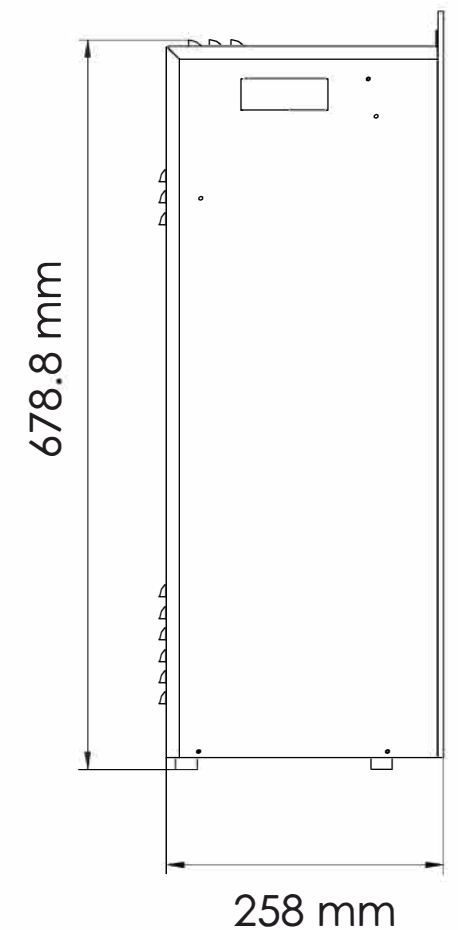
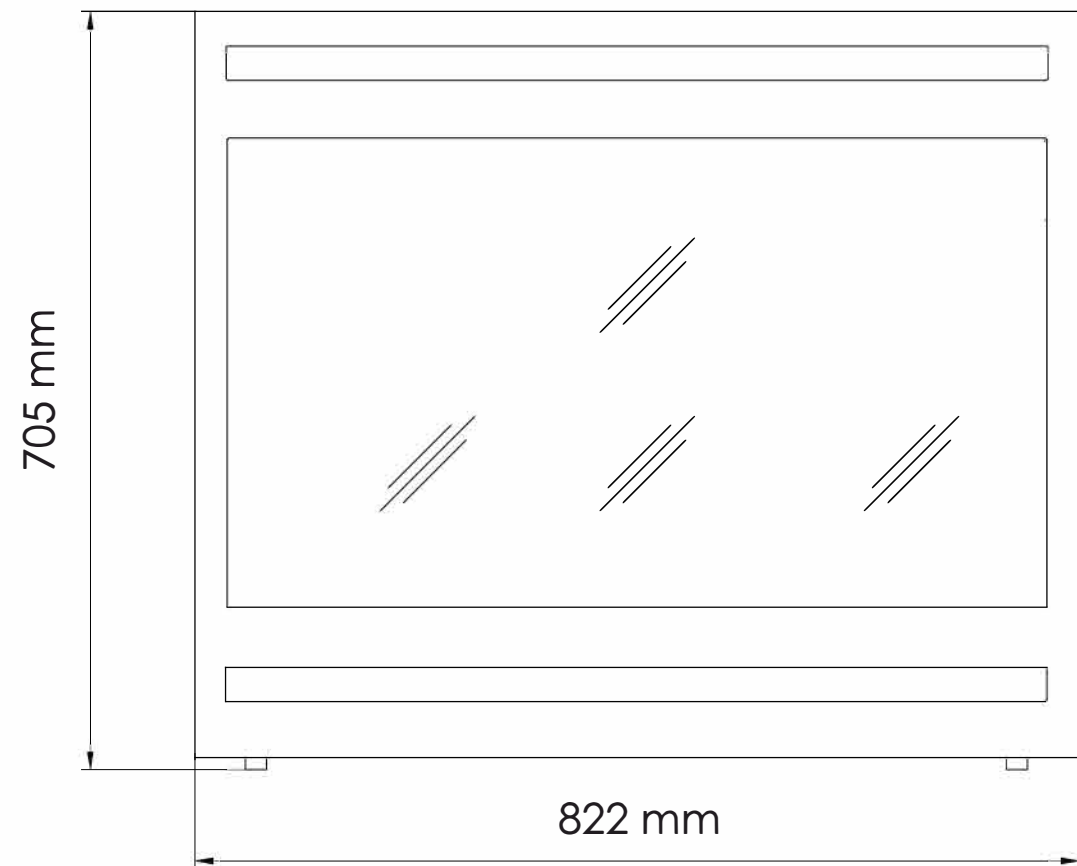

TECHNICAL SPECIFICATIONS		
VOLTS	120	
AMPS	12.5	
WATTS	1 465	
HEATER	HIGH	1 465 watts
	LOW	750 watts
NO HEATER	22 watts	
LAMPS	QUANTITY	LED
	WATTS	
	TOTAL WATTS	22 watts
ROTOR MOTOR	1 at 5 watts	
HEIGHT, WIDTH, DEPTH	67.9 x 76.9 x 25.8 cm	
GLASS VIEWING OPENING		
SURROUND SIZE	82.2 x 70.5 cm	
SHIPPING SIZE	UNIT	76 x 90.5 x 32.5 cm
	STEEL FRONT	76 x 89 x 7.6 cm
SHIPPING WEIGHT	UNIT	28 kgs
	STEEL FRONT	7 kgs
PLUG LOCATION	Left Side	
CORD LENGTH	193 cm	
APPROX. HEATING AREA	37 sqm	



SERIES ZERO CLEARANCE	MODEL ZECL-31-3228-STL-SQR		REV 1
SCALE 1:12	DATE: 12/1/15	SHEET 1 OF 1	